



MODEL C-RD

CEILING DAMPER ROUND

U.L. 555C CLASSIFIED ASSEMBLIES AND ULC S112.2 LISTED

Approved for Assembly ratings of 3-hours or less

Application and Design

The Model C-RD is a round UL Classified ceiling (radiation) damper, butterfly style, approved for steel duct, flex duct and ductless installations in approved UL ceiling designs that incorporate/show a hinged door damper requiring fire/heat protection where HVAC components penetrate the ceiling membrane. These dampers provide protection up to 18" (467mm) diameter openings.



Standard Construction

Frame: 24 Ga. - Galvanized Steel

Blades: 22 Ga. - Galvanized Steel, un-insulated up to 10"

With U.L. classified insulation (Over 10")

Spring: Corrosion resistant steel spring.

Fusible Link: Replaceable 212°F (100°C) standard (others available)

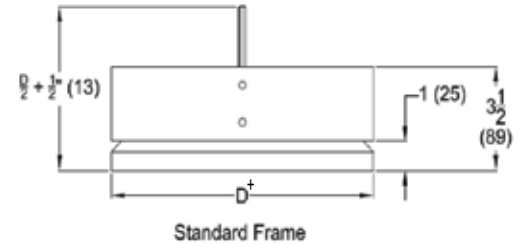

+ Duct Dimension Less 1/16" (1.6mm) unless ordered actual size.

Designed and tested in accordance to standards: UL 555C, ULC S112.2. Labeled and listed by UL/ULC under File #R27747. They meet all the NFPA-90A, IBC Code, and other major code requirements for Ceiling (Radiation) Dampers.

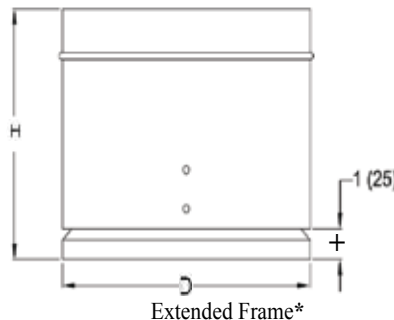

Size (D)	Frame Depth (H)
5" to 10" (127mm to 254mm)	6-3/4" (171mm)
11" to 14" (279mm to 356mm)	8-3/16" (208mm)
15" to 18" (381mm to 457mm)	11-3/4" (298mm)

+ Std is 1". Bottom Extension is 2.5"

Options:

- Volume Adjustment
- Thermal Blanket - 1/8" thick (24 X 24) - CK2000-1 (Required on T-Bar or on surface mtd. diffuser larger than 1" in any direction of diffuser neckopening)
- Alternate Thermal Blanket 1-1/4" Batt (24X24) CK-2000-1B (Required on t-bar or surface mtd. diffuser larger than 1" in any direction of diffuser neck opening)

Min. Size	Max. Size	C/FSR-2 will be supplied for:
5" Diameter 127mm	18" Diameter 457mm	19" Diameter (482mm) and 20" Diameter (508mm)

SUGGESTED SPECIFICATION

Round Ceiling damper's shall be Model C-RD or C-RD-A by CVS. Ceiling dampers shall bear the Underwriters' Laboratories label and be rated for both steel duct and flex duct installations. No external damper supports shall be required for ceiling dampers up to and including 18" (457mm) diameter. Ceiling dampers shall be non-asbestos type and be furnished with a fusible link volume controller where shown (Model C-RD-A).

Manufacturer's Recommendations

All moving parts of the damper must be inspected and cycled once the first year and at intervals not greater than every 4 years or in accordance with the latest edition of NFPA 90A, 92A, local codes and the manufacturer. In addition, fuse links shall be removed and inspected for corrosion. Dry lubricants are recommended.

Job Name:
Location:
Architect:
Engineer:
Contractor:

MODEL C-RD